



art. 65PC

# NEW SIMPLEX

*Ophthalmic Equipments*



TECHNOLOGY AND QUALITY FOR THE BEST COMFORT

# art. 65PC NEW SIMPLEX

Nuovo nel design, completo nelle dotazioni, per una visita oculistica funzionale e confortevole, il riunito New Simplex è quanto di meglio offre il mercato nella qualità e nella convenienza.

*New in the design, complete in the equipments, for a functional and comfortable sight visit, the New Simplex is the better choice on the market in the quality and convenience.*

## SOLUZIONI E CARATTERISTICHE SOLUTIONS AND FEATURES



Soluzione destra e sinistra  
*Right and left solution*



Poltrone disponibili:  
tutti i modelli di poltrona eccetto 88FA  
*Available chairs:  
all models of chairs except 88FA*



Opzional disponibili:  
Braccio autobilanciato orizzontale art. 63AB, 63CD o 63DS  
Caricatore strumenti art. 65PCR  
*Available options:  
Horizontal counterbalanced arm art. 63AB, 63CD or 63DS  
Rechargeable wells art. 65PCR*



NEW CHAIR COLUMN  
NUOVA COLONNA  
DI SOLLEVAMENTO

MAXIMUM HEIGHT  
INCREASED  
MASSIMA ALTEZZA  
AUMENTATA



Pannello di comando riunito  
*Unit control panel*



Alloggiamento oftalmoscopio  
e skiascopio  
*Housing ophthalmoscope  
and skiascope*

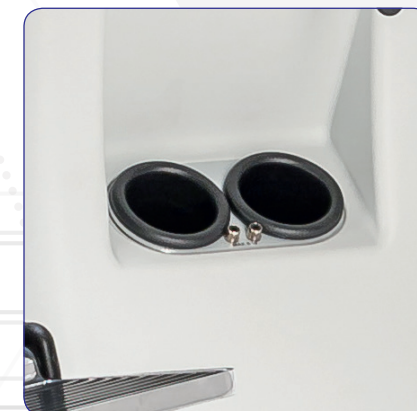

DISPONIBILE ANCHE NELLA  
VERSIONE NEW SIMPLEX **65PD**

Versione 65 PD con tavola singola.

AVAILABLE ALSO VERSION  
NEW SIMPLEX **65PD**

65 PD version with single table.

## technical data

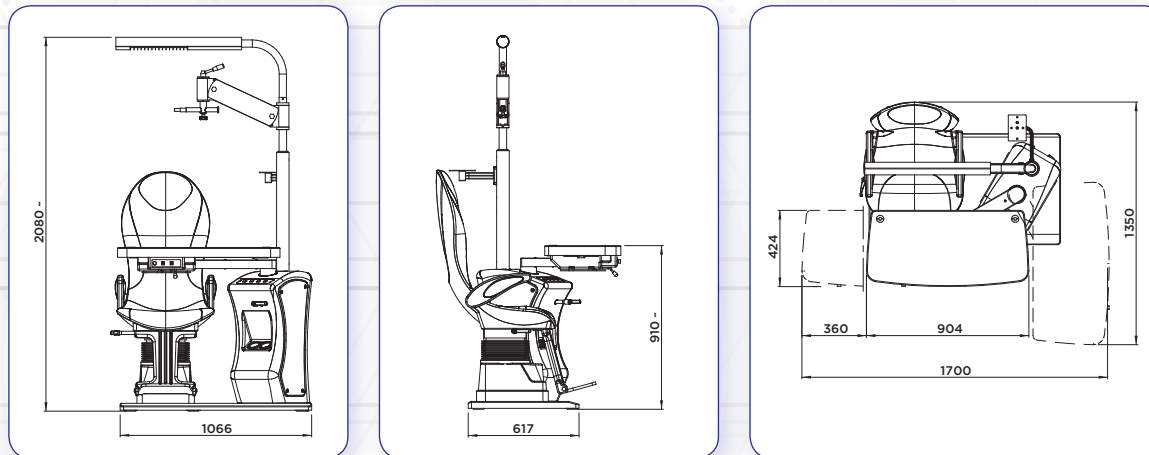

Le dimensioni sono indicative.  
The dimensions are indicative.

Tensione alimentazione / <i>Input tension</i> .....	220V 50-60 Hz. - 110V 50/60 Hz.
Potenza / <i>Power</i> .....	960 VA
Potenza lampada / <i>Lamp power</i> .....	15 W
Altezza tavola / <i>Table height</i> .....	910 mm
Peso / <i>Weight</i> .....	180 kg
Larghezza / <i>Width</i> .....	1700 mm
Profondità / <i>Depth</i> .....	1350 mm
Altezza massima / <i>Maximum height</i> .....	2080 mm

